

MURF820 THRU MURF860

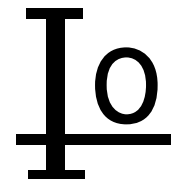

GLASS PASSIVATED SUPER FAST RECTIFIER
Forward Current - 8.0Amperes

FEATURES

- Plastic package has Underwriters Laboratory Flammability Classification 94V-0
- Fast switching for high efficiency
- Low forward voltage drop
- Single rectifier construction
- High surge capability
- For use in low voltage ,high frequency inverters, free wheeling ,and polarity protection applications
- High temperature soldering guaranteed:260 C/10 seconds, 0.25"(6.35mm)from case
- Component in accordance to RoHS 2011/65/ EU

* Lead Free Finish/RoHS Compliant

MECHANICAL DATA

- Case: JEDEC ITO-220AC molded plastic body
- Terminals: Lead solderable per MIL-STD-750,method 2026
- Polarity: As marked
- Mounting Position: Any
- Weight: 1.78 gram

VOLTAGE RANGE

200 to 600Volts

CURRENT

8.0Ampere

ITO-220AC

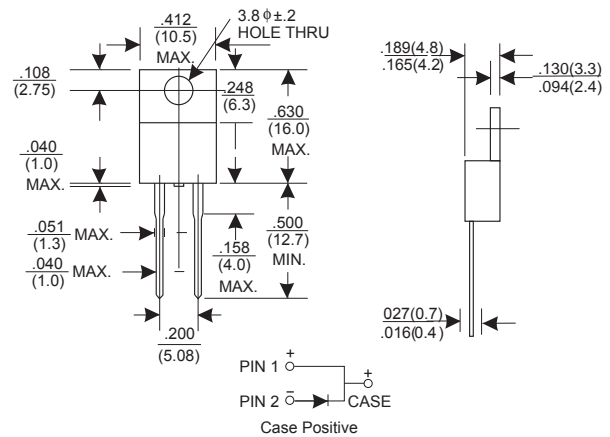

Dimensions in inches and (millimeters)

MAXIMUM RATINGS AND ELECTRICAL CHARACTERISTICS

(Ratings at 25°C ambient temperature unless otherwise specified ,Single phase ,half wave ,resistive or inductive load. For capacitive load,derate by 20%.)

	Symbols	MURF 820	MURF 840	MURF 860	Units
Maximum repetitive peak reverse voltage	V _{RRM}	200	400	600	Volts
Maximum RMS voltage	V _{RMS}	140	280	420	Volts
Maximum DC blocking voltage	V _{DC}	200	400	600	Volts
Maximum average forward rectified current(see Fig.1)	I _(AV)	8.0			Amps
Peak forward surge current 8.3ms single half sine-wave superimposed on rated load (JEDEC method)	I _{FSM}	125			Amps
Maximum instantaneous forward voltage at 8.0 A(Note 1)	V _F	0.975	1.3	1.7	Volts
Maximum instantaneous reverse current at rated DC blocking voltage(Note 1)	I _R	T _A = 25°C	5		uA
		T _A = 125°C	10		
Maximum Reverse Recovery Time (Note 2)	T _{rr}	35			ns
Typical thermal resistance (Note 3)	R _{θJC}	2.5			°C/W
Operating junction temperature range	T _J	-40 to+ 150			°C
Storage temperature range	T _{STG}	-40 to+ 150			°C

- Notes: 1. Pulse test: 300μ s pulse width, 1% duty cycle
2. Reverse recovery test conditions I_F=0.5A,I_R=1.0A, I_{rr}=0.25A
3. Thermal resistance from junction to case

RATINGS AND CHARACTERISTIC CURVES MURF820 THRU MURF860

FIG.1-FORWARD CURRENT DERATING CURVE

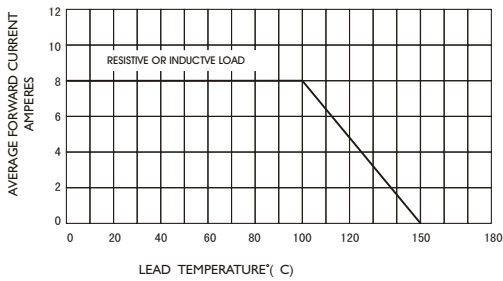

FIG.2-MAXIMUM NON-REPETITIVE PEAK FORWARD SURGE CURRENT

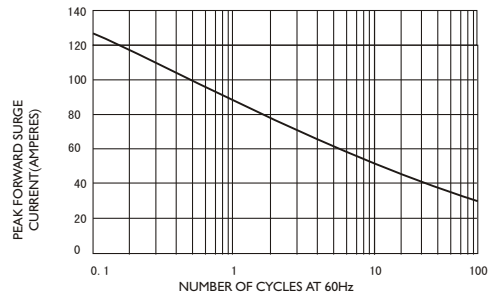

FIG.3-TYPICAL INSTANTANEOUS FORWARD CHARACTERISTICS

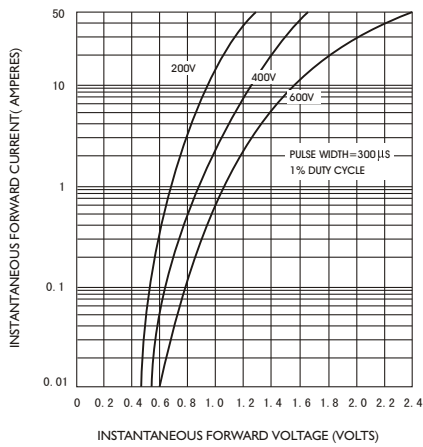

FIG.4-TYPICAL REVERSE CHARACTERISTICS

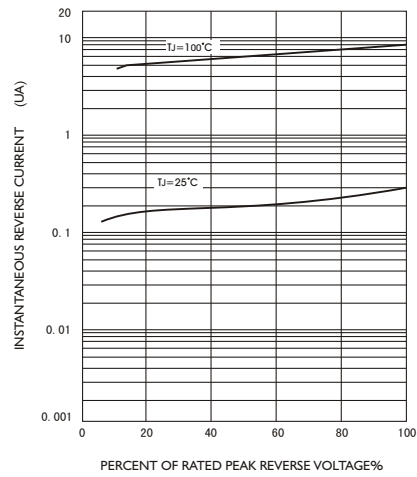

FIG.5-TYPICAL JUNCTION CAPACITANCE

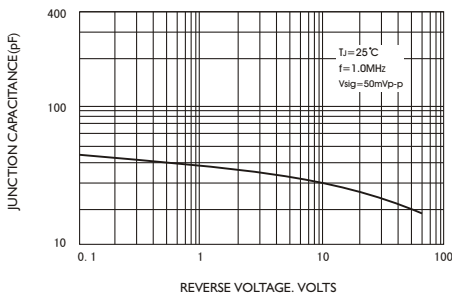

FIG.6-TYPICAL TRANSIENT THERMAL IMPEDANCE

