

MBR30150LCT

LOW VF TRENCH SCHOTTKY BARRIER RECTIFIER

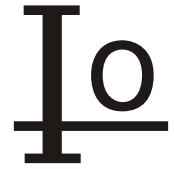

Features

- Schottky Barrier Diodes
- 30 A Total (15A Per Diode Leg)
- Guard Ring for Stress Protection
- Low Forward Voltage
- 175°C Operating Junction Temperature
- Epoxy Meets UL 94 V 0 @ 0.125 in
- Low Power Loss/High Efficiency
- High Surge Capacity
- Low Stored Charge Majority Carrier Conduction
- Pb Free Packages are Available*

Mechanical Characteristics:

- Case: Epoxy, Molded
- Weight: 1.81 grams (approximately)
- Finish: All External Surfaces Corrosion Resistant and Terminal Leads are Readily Solderable
- Lead Temperature for Soldering Purposes: 260°C Max. for 10 Seconds

VOLTAGE

150 Volts

CURRENT

30.0 Ampere

TO-220AB

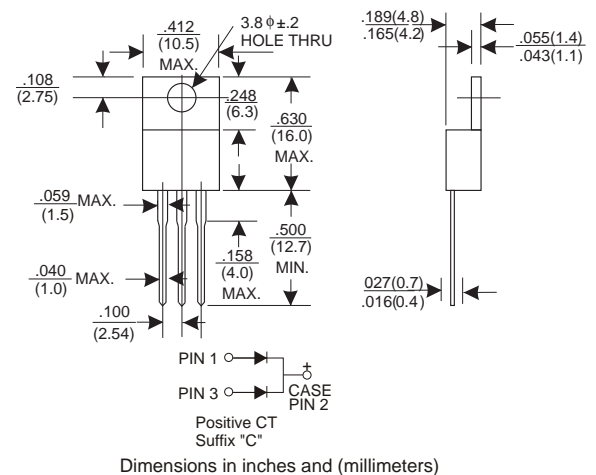

MAXIMUM RATINGS AND ELECTRICAL CHARACTERISTICS

Rating	Symbol	MBR30150LCT	Unit
Peak Repetitive Reverse Voltage	V_{RRM}	150	V
Average Rectified Forward Current (Rated V_R) $T_C = 133^\circ\text{C}$	$I_{F(AV)}$	15	A
Peak Repetitive Forward Current (Rated V_R , Square Wave, 20 kHz) $T_C = 133^\circ\text{C}$	I_{FRM}	30	A
Maximum Instantaneous Forward Voltage ($i_F = 15\text{Amps}$, $T_C = 25^\circ\text{C}$)	V_F	0.85	V
Nonrepetitive Peak Surge Current (Surge applied at rates load conditions halfwave, single phase, 60Hz)	I_{FSM}	250	A
Peak Repetitive Reverse Surge Current (2.0 μs , 1.0 kHz)	I_{RRM}	5	A
Operating Junction Temperature	T_J	- 65 to +175	$^\circ\text{C}$
Voltage Rate of Change (Rated V_R)	dv/dt	10,000	$\text{V}/\mu\text{s}$
Maximum Instantaneous Reverse Current (Rated dc Voltage, $T_C = 125^\circ\text{C}$)	I_R	6.0	mA
(Rated dc Voltage, $T_C = 25^\circ\text{C}$)		0.05	

MBR30150LCT

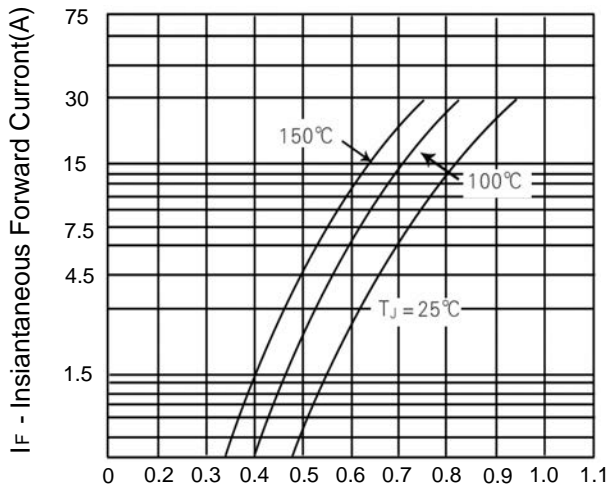

Figure 1. Typical Forward Voltage Per Diode

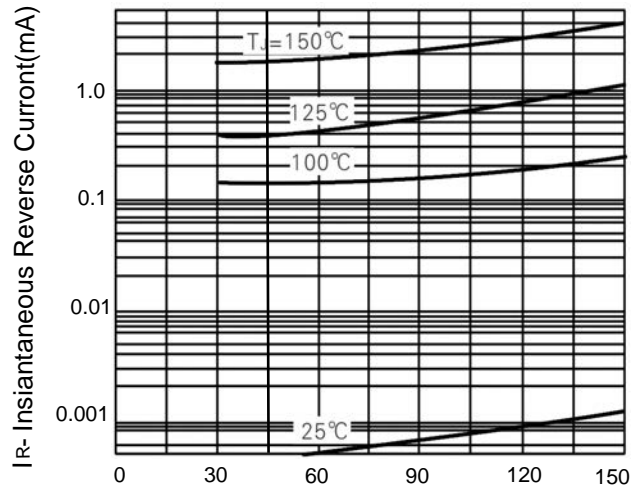

Figure 2. Typical Reverse Current Per Diode

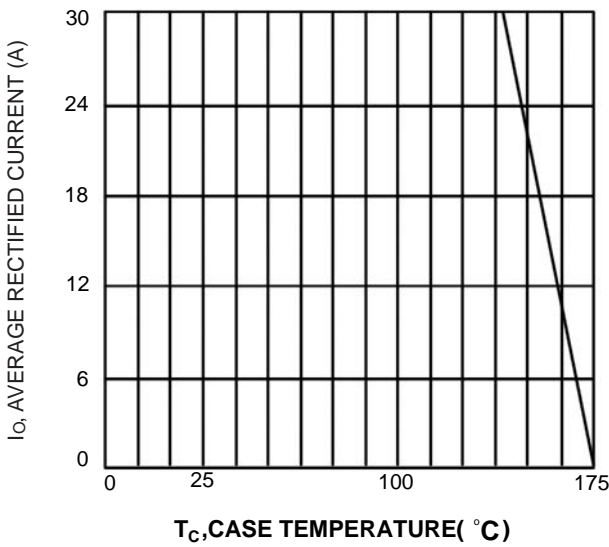

Fig.3 Forward Current Derating Curve

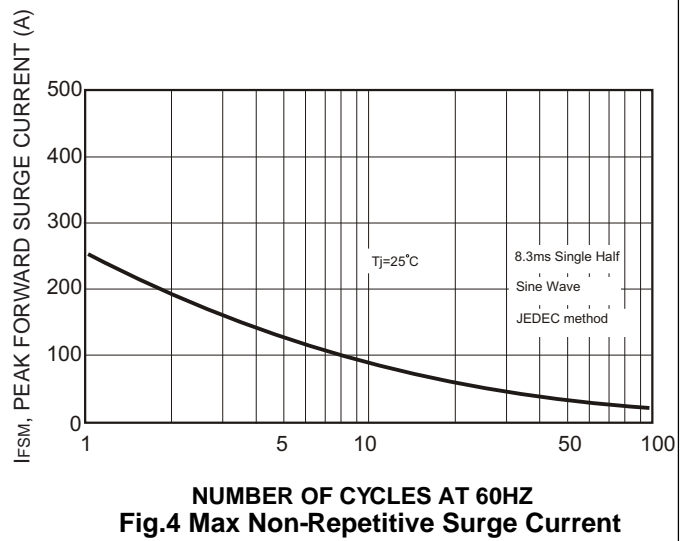

Fig.4 Max Non-Repetitive Surge Current