

# US3A THRU US3M

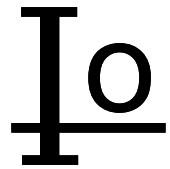

## 3.0 AMP HIGH EFFICIENCY RECTIFIERS



### FEATURES

- \* Ideal for surface mount applications
- \* Easy pick and place
- \* Built-in strain relief
- \* High surge current capability

### MECHANICAL DATA

- \* Case: Molded plastic
- \* Epoxy: UL 94V-0 rate flame retardant
- \* Terminals: Solder plated, solderable per MIL-STD-202F, method 208 guaranteed
- \* Polarity: Color band denotes cathode end
- \* Mounting position: Any
- \* Weight: 0.215 grams
- \* Lead Free Finish/RoHS Compliant

### VOLTAGE RANGE

50 to 1000 Volts

### CURRENT

3.0 Amperes

#### DO-214AB(SMC)

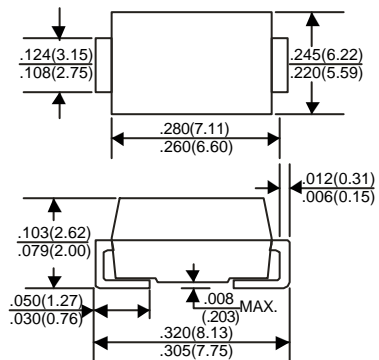

Dimensions in inches and (millimeters)

## MAXIMUM RATINGS AND ELECTRICAL CHARACTERISTICS

Rating 25 C ambient temperature unless otherwise specified.  
Single phase half wave, 60Hz, resistive or inductive load.  
For capacitive load, derate current by 20%.

TYPE NUMBER	US3A	US3B	US3D	US3G	US3J	US3K	US3M	UNITS
Maximum Recurrent Peak Reverse Voltage	50	100	200	400	600	800	1000	V
Maximum RMS Voltage	35	70	140	280	420	560	700	V
Maximum DC Blocking Voltage	50	100	200	400	600	800	1000	V
Maximum Average Forward Rectified Current	3.0							A
Peak Forward Surge Current, 8.3 ms single half sine-wave superimposed on rated load (JEDEC method)	100							A
Maximum Instantaneous Forward Voltage at 3.0A	1.0		1.3		1.70			V
Maximum DC Reverse Current Ta=25 C	5.0							μA
at Rated DC Blocking Voltage Ta=100 C	150							μA
Maximum Reverse Recovery Time (Note 1)	50				75			nS
Typical Junction Capacitance (Note 2)	75							pF
Operating and Storage Temperature Range Tj, TSTG	-65 — +150							C

#### NOTES:

1. Reverse Recovery Time test condition: IF=0.5A, IR=1.0A, IRR=0.25A
2. Measured at 1MHz and applied reverse voltage of 4.0V D.C.

# RATING AND CHARACTERISTIC CURVES (US3A THRU US3M)

FIG.1-TYPICAL FORWARD CHARACTERISTICS

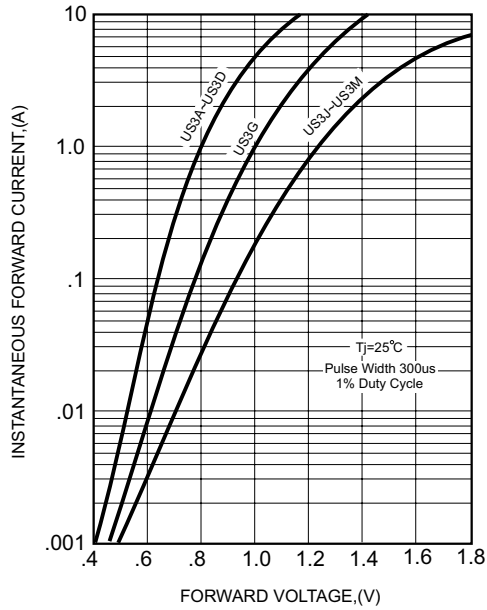

FIG.2-TYPICAL FORWARD CURRENT DERATING CURVE

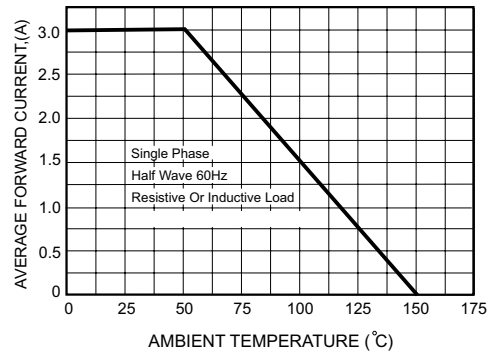

FIG.4-MAXIMUM NON-REPETITIVE FORWARD SURGE CURRENT

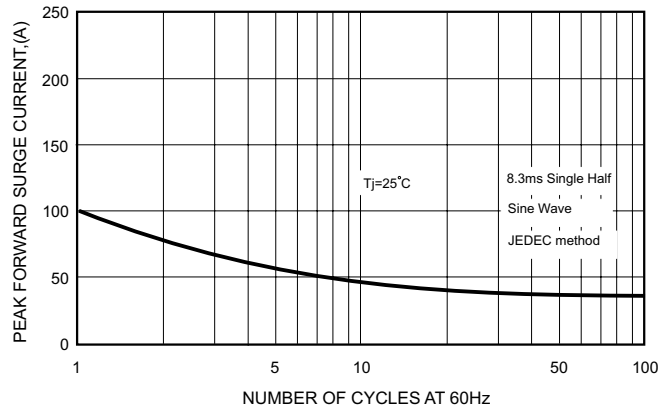
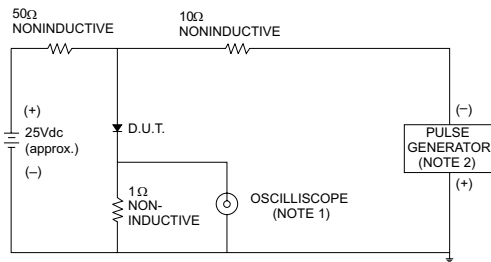

FIG.3- TEST CIRCUIT DIAGRAM AND REVERSE RECOVERY TIME CHARACTERISTICS



- NOTES: 1. Rise Time= 7ns max., Input Impedance= 1 megohm, 22pF.  
2. Rise Time= 10ns max., Source Impedance= 50 ohms.

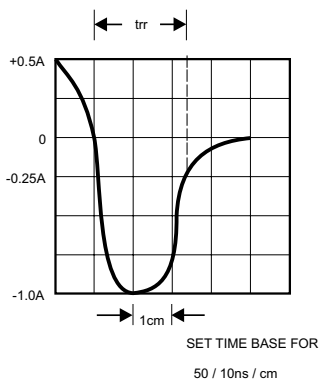

FIG.5-TYPICAL JUNCTION CAPACITANCE

